

# **Design of steel piles for integral abutment bridges using Eurocodes**

Hans Pétursson

## **ABSTRACT**

Integral Abutment Bridges are becoming more popular in Europe, but the traditions differ from country to country. This leads to different technical solutions for the same problem in each country.

In this paper some of the different solutions that are used in Europe are presented.

The Eurocodes are set of technical rules for the structural design of construction works. Since 2010 the Eurocodes are mandatory for specification of public works and are intended to be the standard used in all the EU zone for the design of construction works. There are no special rules for bridges with integral abutments in the Eurocodes for integral abutment bridges. It is up to the designer to come up with a design that complies with the rules in the Eurocodes that are common with other type of bridges. In this paper some of the aspects of designing piles according to Eurocodes are described.

## INTRODUCTION

### Pile types used in Europe

European experience with integral abutment bridges (IAB) is significantly less than in some states in USA, but what experience has been gained has been positive. As a result, the trend is towards making IAB a larger percentage of all newly constructed bridges across Europe.

To broaden the knowledge base for IAB design and construction, the International Workshop on Integral Abutment Bridges was held in Stockholm, Sweden in May of 2006 (Collin et. al. 2006). Designers and researchers from eight different countries participated in the workshop. The goal of the workshop was to share the experiences of the participants and to further the understanding of the design, construction, and maintenance of IAB.

During the workshop, it became clear that each country represented a slightly different approach to the design of IAB. In spite of the different viewpoints, each representative indicated that their designs were successful and stated that they would be constructing additional IAB in the future.

It should be pointed out that integral abutments are still quite new in most European countries. There are few standards yet. The experiences from other bridge foundations types are the starting point from which engineers in Europe apply the concept of integral abutments.

Pile foundations are not always required in Europe for FIAB. This is in direct contradiction to many USA agency requirements. Many US agencies require the piles to be placed in a single row (Maruri et. al. 2005) on the belief that the single row permits the abutment stem to translate into and out of the soil while also permitting rotation of the abutment stem. Spread footings, by their very nature, restrain the rotation of the abutment stem (see Figure 1). In the United Kingdom, however, spread footings are the preferred foundation for FIAB on the belief that the bridge and the approach pavement will settle equally. There have not been any reported problems related to the restrained abutment rotations.

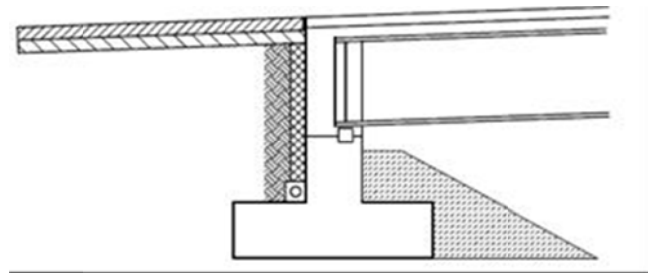

Figure1. Example of an Integral Abutment on Spread Footing Used in the United Kingdom (Iles 2005)

Despite the success in the UK, most European countries use a pile supported foundation for their FIAB. The European Survey indicates that designers account for the bending forces in the piles. In most European countries, empirical design is not permitted, and the function of the bridge must be verified by calculations. Although there are no requirements for the procedure, designers typically create a computer finite element model using theoretical springs to represent the soil supporting the pile along its length, as well as the filling behind the back wall.

The design philosophy varies between different countries and that is reflected in their choice of pile. Some countries strive to make the piles stiff to resist the stresses induced from the abutment translation and rotation while others choose slender piles in an attempt to lessen the impact of the piles on the overall structure. For example, England, Ireland, and Sweden use

sleeves around the piles to prevent soil from restraining the free bending of the piles during superstructure translation. This theoretically distributes any longitudinal translation and rotation along a greater length of the pile, thereby reducing the moment induced in the pile. Without the soil to prevent the buckling of the pile, this method of construction may require stronger piles to accommodate the unsupported length.

The following is a listing of the various pile types that are used with FIAB in Europe:

#### **X-piles**

Cross-shaped steel piles, also called X-piles, have been used in integral bridges in Sweden. The X-shaped piles are driven vertically and rotated 45° in order to minimize the bending stresses. This pile type is being discontinued by the manufacturer, thus it will not be used in the future.

#### **H-piles**

H-piles are not commonly used in Europe. This practice is quite different from the USA, where more than 70% of State agencies reported (Maruri et. al. 2005) using steel H-piles for a majority of their integral abutments. When they use piles, England and Ireland use steel H-piles with the strong axis perpendicular to the bridge expansion.

#### **Small Diameter Pipe Piles**

Small diameter pipe piles are not commonly used for FIAB in Europe or the USA. Small diameter pipe piles may be drilled or driven. In rocky soil, it is best to pre-drill for the piles when precise location is important.

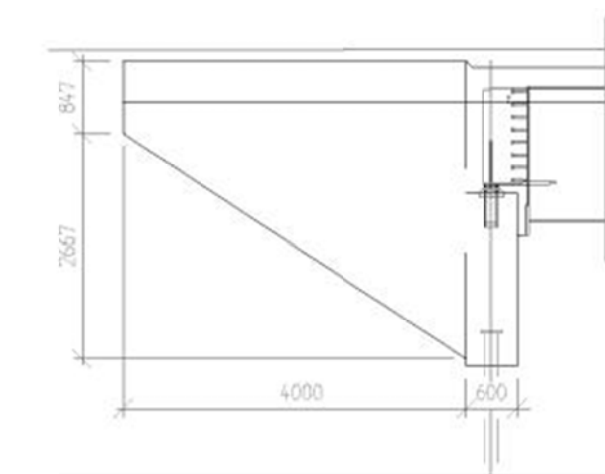

Figure 2. Swedish Integral Abutment Detail with Small Diameter Steel Pipe Piles

#### **Large Diameter Steel Pipe Piles**

Large diameter steel pipe piles filled with reinforced concrete are the most common pile type used in Europe. In Finland, more than 1,000 jointless bridges have been built in the last ten years (Kerokoski 2006), and a large percentage of them rest on reinforced concrete filled steel pipe piles. These steel pipe piles are typically 2.25 ft. (700 mm) in diameter but can be up to 4.0 ft. (1.2 m) in diameter. If the distance to the bedrock is short, pipe piles can be used as shown in Figure 4. In this case, the design usually assumes that the large diameter piles provide fixity at the beam ends, and the beam's mid-span moments decrease while the end moments increase.



Figure 3. Finnish Bridge with Large Diameter Steel Pipe Piles During Construction

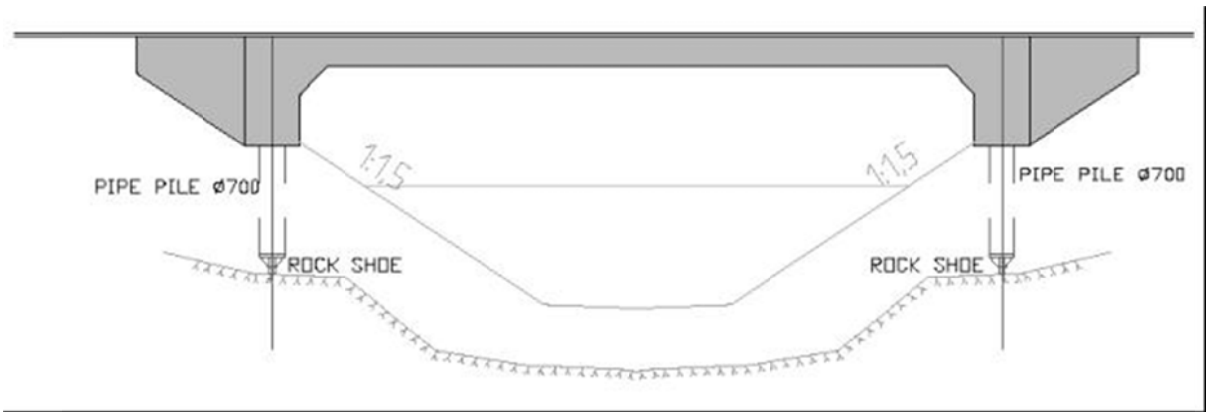

Figure 4. Short pipe piles on rock, Sweden

### **Cast-In-Place Reinforced Concrete Piles**

Cast-in-place concrete piles are used in some European countries. In Germany, large diameter cast-in-place piles are used to constrain end rotation and lower the mid-span beam moments. An example can be seen in Figure 9. These piles typically have a diameter of 900 mm. The desired constraint could also be obtained by using wide spread footings.

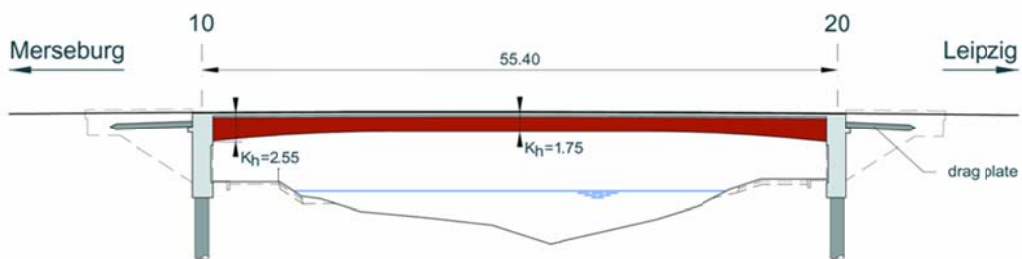

Figure 5. Sketch of German bridge with reinforced cast in-situ concrete piles.

### **Precast and Prestressed Concrete Piles**

Precast (PC) and prestressed (PS) concrete piles are not commonly used in Europe, with the exception of Sweden. In Sweden, PC/PS concrete piles are common in all bridge types, including short FIAB, due to their low cost and ready availability. In the USA, these pile types are typically only used for shorter span FIAB.

### **Steel Core Piles**

Although not common, steel core pipe piles have been used for FIAB in Europe. The pile system consists of a cover pipe, injected concrete and a core steel pile. Drilling is performed down to the bedrock. The cover pipe is drilled 300-500 mm into the rock. When the cover pipe is placed in the hole the interior is rinsed and then injected with concrete. The steel core is then installed. After inspection and driving pile to refusal the pile is cut to the right length. A pressure distribution plate is then fit to the top of the pile. In this way the very slender steel pile can be used and the concrete stabilizes the pile from buckling. A few FIAB have been built in Sweden with steel core piles.

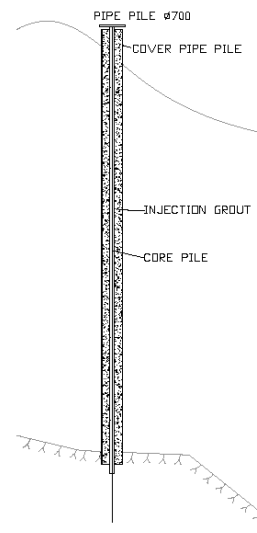

Figure 6. Sketch of steel core pile.

## **The Eurocodes**

The Eurocodes are set of technical rules for the structural design of construction works. Since 2010 the Eurocodes are mandatory for specification of public works and are intended to be the standard used in all the EU zone for the design of construction works. The Eurocodes are published separate European Standards each section having a number e.g. EN 1990 Basis of structural design, EN 1991 Actions on structures, 1992 Design of Concrete Structures and EN 1993 Design of Steel Structures. There are 10 sections published and each section consists of several parts.

There are no specific parts of the Eurocodes that deals with integral abutments nor are there any specific rules in the different parts. It is up to the designer to come up with a design that complies with the rules in the Eurocodes that are common with other type of bridges. The parts of the Eurocodes that the designer needs to look into when designing piles for integral abutment bridges are:

EN 1990 Basis of structural design

EN 1991-2 Actions on structures - Part 2: Traffic loads on bridges

EN 1991-5 Actions on structures - Part 1-5: General actions - Thermal actions  
EN 1993-2 Steel bridges  
EN 1993-5 Design of steel structures - Part 5: Piling  
EN 1997-1 Geotechnical design - Part 1: General rules

## **Design of piles**

### **Philosophies**

Integral abutment bridges may be generally designed based on two different concepts.

#### *1. Low flexural stiffness of piles / low degree of restraint*

If the integral abutment is supported by one row of flexible piles the superstructure can be analyzed as a beam with simple hinged supports.

#### *2. High flexural stiffness of piles / high degree of restraint*

If the integral abutment is supported on stiffer piles or spread footing the rotation of the superstructure and to some extent the displacement will be restrained and a large support moment will be distributed to the superstructure. This means that the connection between the abutment and the superstructure needs to be stronger and more robust but the field moment of the superstructure is somewhat shifted to the support and a more slender superstructure can be constructed. If the piles are relatively short and stiff enough the structure acts like a frame and the soil-bridge interaction is not as vital as in bridges with more slender piles. This type is not discussed further in this paper.

### **Loading**

Bridge loading is the same for integral abutment bridges as other bridges. The difference is that some loads cause forced displacement and rotations at the top of the piles and this gives unwanted strains in the piles. The stiffness behind the abutment relieves these strains to some extent depending on confinement, water content and friction.

### **Thermal loads**

Two types of temperature loads need to be considered. First, a uniform temperature change which means that the abutment is displaced horizontally. The magnitude of the bridge movement depends on the mean temperature of the structure when the superstructure is locked to the abutments. Also uneven temperature distribution in the superstructure causes movements of the piles as the beam end rotates. The mean bridge temperature is dependent on the ambient air temperature, wind effect and solar radiation. Temperature gradients through the depth of the bridge beams generate secondary bending moments due to the fact that the centroid of the temperature distribution curve and the centroid of the cross-section of the bridge beams may not coincide. The maximum temperature differentials (with positive gradient) occurs when the concrete deck slab is exposed to sun radiation during the summer and winter, resulting in a concrete deck slab that is warmer than the steel beams. The minimum temperature differential (with negative gradient) occurs when the concrete deck slab is suddenly drenched with cold rain or snow, thus cooling the concrete deck slab at a faster rate than the steel beams. The rotation will also cause a horizontal displacement of the pile top if there is a vertical distance between the centre of gravity of the composite cross-section and lower edge of the abutment wall where the pile is clamped.

The temperature of the bridge varies continuously. The seasonal variations have the largest amplitude, but a small number of cycles. A bridge lifetime is estimated to be 120 years, which gives 120 stress cycles of annual temperature variations. The daily variations are more frequent and will induce  $365 \times 120 = 43\,800$  stress cycles. The width of temperature cycles are not constant and the width of annual temperature cycles are (of course) larger than the width of the daily temperature cycles. It is not common to measure the bridge temperature and it is thus valuable to have models to estimate the bridge temperature from ambient temperature. The estimation is mostly based on the shade air temperature but there are more sophisticated models also. In Eurocode EN 1991-1-5 (CEN 2003) a diagram like in Figure 1 is presented to estimate the maximum and minimum uniform bridge temperature components  $T_{e,min}$  and  $T_{e,max}$ .

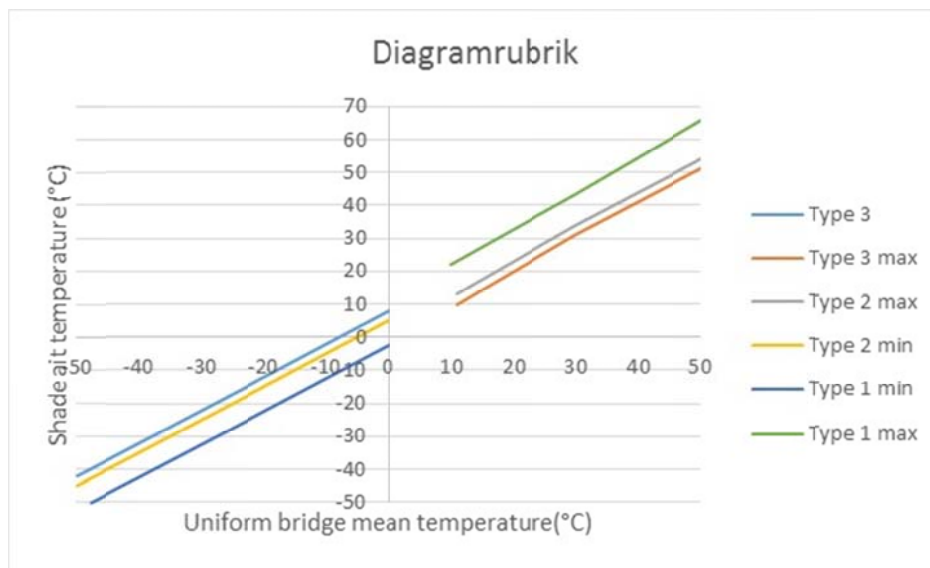

Figure 7. Correlation between minimum/maximum shade air temperature and mean bridge temperature.

Bridge decks are grouped in three different groups in Eurocode EN 1991-1-5 (CEN 2003) for the purpose of differentiating between massive bridge deck that take longer time to heat and cool from lighter bridge decks that are more rapidly heated and cooled. The three groups are Type 1: Steel deck, Type 2: Composite deck and type 3: Concrete deck. As seen in Figure 1 the maximum/and minimum bridge temperatures are  $5^\circ\text{C}$  above the corresponding shade air temperatures for type 2 while the range is larger for Type 1 and smaller for Type 3. The overall range of the uniform bridge temperature:

$$T_N = T_{e,max} - T_{e,min} \quad (1)$$

The shade air temperature used for design is a temperature with the annual probability of being exceeded of 0,02 or once in 50 years. As an example value for Stockholm, Sweden is  $T_{e,max} = 36^\circ\text{C}$  (TRVFS) and  $T_{e,min} = -29^\circ\text{C}$  and the range of the bridge temperature thus becomes  $75^\circ\text{C}$ . As can be seen in Table 4 the maximum annual temperature width for the past 52 years is  $56.6^\circ\text{C}$  (Moberg et. al. 2002) and the design values can thus be regarded as conservative.

TABLE I . TEMPERATURE MEASUREMENTS IN STOCKHOLM 1961-01-01-2012-12-31  
(MOBERG ET. AL. 2002).

	Daily temperaturers					Annual temperature changes.	
	T <sub>max</sub>	T <sub>min</sub>	T <sub>mean</sub>	ΔT <sub>daily</sub>	ΔT <sub>mean</sub>	ΔT <sup>1</sup>	T <sup>2</sup>
Max.	35.4	22.4	28.3	20.4	14	56.6	46.6
Min.	-22.1	-25.5	-23.9	0.3	0	32	23.5
Mean	10.5	4.1	7.1	6.3	1.7	45.8	36.1
Median	10.0	4.0	6.9	5.9	1.3	46.2	36.1

In Eurocode EN 1991-1-5 (CEN 2003) the maximum and minimum temperatures are based on daily temperature ranges of 10° C which is 13% of the maximal annual temperature width. Measurements in the UK (Emerson 1977) showed that the daily temperature widths in a composite bridge as most were about 25% of the annual.

### Traffic loads

In this paper only road bridges are considered, in the Eurocodes railway loads and loads for pedestrian bridges are also covered. For road bridges there are two load models that represents the most severe traffic expected in practice on the main routes of European countries. There are two adjustment factors  $\alpha$  and  $\beta$  to adjust the loads to differences between countries and different roads. Only one load model is described here as it the only one that is used for pile design.

### Load model 1

Load model 1 consist of two axle loads,  $Q_{ik}$ , and a distributed load  $q_{ik}$  with values in each lane according. Each lane is 3 m wide and the distance between axles is 1.20 m.

TABLE II . LOAD VALUES FOR THE TRAFFIC

Location	Tandem system <i>TS</i>	<i>UDL</i> system
	Axle loads $Q_{ik}$ (kN)	$q_{ik}$ (or $q_{ik}$ ) (kN/m <sup>2</sup> )
Lane Number 1	300	9
Lane Number 2	200	2,5
Lane Number 3	100	2,5
Other lanes	0	2,5
Remaining area ( $q_{ik}$ )	0	2,5

### Parameters of soil surrounding the piles

According to the Eurucodes (EC 1997-1 7.7.3) “*The calculation of the transverse resistance of a long slender pile may be carried out using the theory of a beam loaded at the top and supported by a deformable medium characterised by a horizontal modulus of subgrade reaction*”

<sup>1</sup>Calculated from maximum and minimum readings.

<sup>2</sup>Calculated from daily mean estimations.



### Soil with cohesion (clay)

If the soil surrounding the soil is considered to be an elastic continuum with Young's modulus  $E$  and Poisson's ratio of 0.5 the lateral soil modulus,  $k_u$ , can be derived e.g. according to Baguelin (1997). If the Young's modulus is supposed to be  $E=50c_u$ , where  $c_u$  is the cohesion the lateral soil modulus can be written:

$$k_u = k_0 c_u / b, \quad 157 \leq k_0 \leq 242 \quad (2)$$

For long term loading the creep effect must be considered. This done approximately by reducing the lateral soil stiffness:

$$k_u = 50 c_u / b \quad (3)$$

The pressure against the pile is described by the expression:

$$p = k_u u \quad (4)$$

Where  $u$  is the lateral displacement of the pile. The pressure  $p$  is limited to a value  $p_y$  that for drained conditions can be calculated by:

$$p_y = N_c c_u \quad (5)$$

Where  $N_c$  is a constant that varies between 8-12 for deep soil layers ( $<3b$ ) and decreases to 2 for layers closer to the surface. For short time loading  $N_c=9$  can be used and for long time loading the creep is considered by a lower value of  $N_c=6$ .

### Cohesion-less soil (friction soil)

For cohesion-less soils there are no unambiguous expression that describes the relation between the lateral soil modulus and the strength parameter  $\sigma'_c$ . The relationship between lateral displacement and soil pressure against the pile is therefor based on suggested empirical "p-y" curves based on experimental data. There are numerous suggestions on different "p-y" curves among them are Reese (1994). The "p-y" curves are un-linear and a soil model with linear curve based the initial slope of the "p-y" curve suggested by Reese et. al.(1994) is used here. The lateral soil modulus is half of the initial modulus according to Reese et. al.(1994) and is expressed as follows:

$$K_u = 1/2 k_s z \quad (6)$$

where  $k_s$  is given in Table III.

TABLE III. VALUES FOR THE CONSTANT  $K_s$  FOR LATERAL SOIL MODULUS ACCORDING TO REESE ET. AL. (2007)

	Water [MN/m <sup>3</sup> ]	Sand above water table [MN/m <sup>3</sup> ]
Loose sand	5	7
Medium dense sand	16	24
Dense sand	34	61

For un-drained conditions the limit value is calculated by:

$$p_y = N_{\square} \sigma'_v \quad (7)$$

where  $\sigma'_v$  is the vertical soil pressure and  $N = 3K_p$ . Creep is not considered for friction soils.

### Modelling the pile abutment connection

The connection between the pile and the abutment can be modelled as fixed or pinned connection. Experiments at Lulea University of Technology (Pétursson et. al. 2013) using full-scale models of clamped piles demonstrated that a steel pipe pile can accommodate large inelastic deformations under strains six times greater than the yield strain for several hundred load cycles. This indicates that by permitting pile strains in excess of the yield strain (which is not permissible under most current design codes), integral abutment bridges could be erected with several hundred meters of bridge length. Considering that the fixity of the pile is somewhere between rigidly fixed and pinned it is practical to consider the connection as pinned and design the pile with normal force, displacement and an external moment at the top of the pile.

### Modelling the pile soil interaction

In the suggested analytical model to design the pile it is assumed that the largest displacements take place near the pile head and thus the largest soil pressure against the pile also is at the upper part of the pile. As soon as the limit value,  $p_y$ , of the soil pressure is obtained the lateral soil modulus will behave plastic at further displacement of the pile top (see Figure 9). The pile will behave elastic until a plastic hinge is formed somewhere along the pile and then the pile capacity is reached. To reach this state the pile must be ductile and belong to Class 1 cross-section according to EN 1993-1-1.

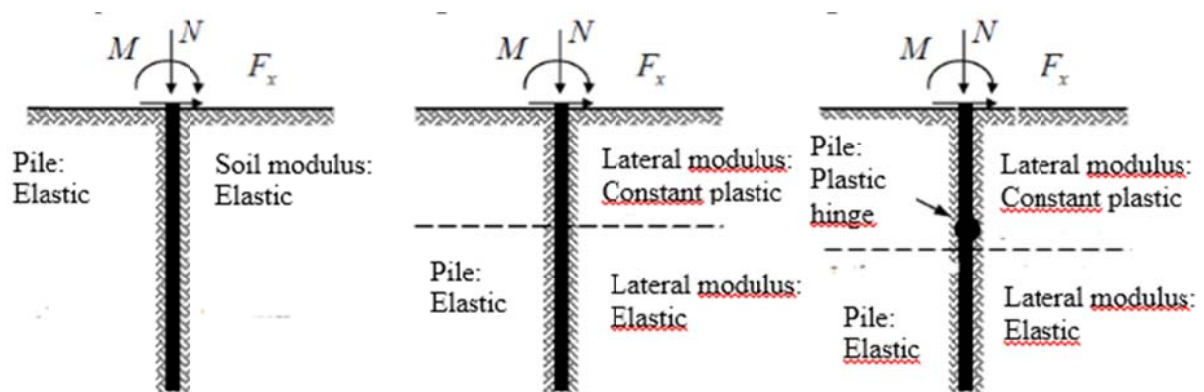

Figure 8. Three stages for the pile analysis, low load at the left, intermediate load in the middle and large load at the right.

The procedure to calculate the moments and shear forces along the pile considering second order effects is an iterative process that is preferably done with computer programs.

## Initial imperfections and second order moments

When designing piles second order effects are taken into consideration. This is done by enlarging moment along the pile and is depending on the initial imperfections of the pile. The initial imperfection of the pile can be assumed according to Table 5.1 in EN 1993-1-1 and is: 1/200

$$e_0/l_c=1/200 \quad (8)$$

for steel pipe piles that are cold formed. For piles with H-profile the value is 1/300 for strong axis bending and 1/250 for weak axis bending.

## Concluding remarks

This paper describes some of issues that have to be dealt with when designing steel piles for integral abutment bridges, but is far from complete. For a more comprehensive material about designing integral abutments according to Eurocodes the reader can look into the design guide from the INTAB project Feldman et. al 2010.

## REFERENCES

- Baugelin F, Frank R, Said Y. H., 1977, Theoretical study of lateral reaction mechanics of piles, *Geotechnique*, Vol. 3, pp. 405-434
- Collin P., Veljkovic M., Petursson H., 2006, "International Workshop on Bridges with Integral Abutments", Lulea University of Technology, ISSN: 1402-1536, ISRN: LTU-TR06/14-SE
- EN 1990 // Eurocode - Basis of structural design. - Brussels : European Committee for Standardization (CEN), 2002.
- EN 1990/A1 Eurocode - Basis of structural design, Annex A2: Application of bridges (normative). - Brussels : European Committee for Standardization (CEN), 2006.
- EN 1991-1-5 // Eurocode 1: Actions on structures - Part 1-5: General actions – Thermal actions. - Brussels : European Committee for Standardization (CEN), 2003.
- EN 1991-2 // Eurocode 1: Actions on structures - Part 2: Traffic loads on bridges. - Brussels : European Committee for Standardization (CEN), 2003.
- EN 1992-1-1 // Eurocode 2: Design of concrete structures - Part 1-1: General rules and rules for buildings. - Brussels : European Committee for Standardization (CEN), 2004.
- EN 1992-2 // Eurocode 2 - Design of concrete structures - Concrete bridges - Design and detailing rules. - Brussels : European Committee for Standardization (CEN), 2005.
- EN 1993-1-1 // Eurocode 3: Design of steel structures - Part 1-1: General rules and rules for buildings. - Brussels : European Committee for Standardization (CEN), 2005.
- EN 1993-1-5 // Eurocode 3 - Design of steel structures - Part 1-5: Plated structural elements. - Brussels : European Committee for Standardization (CEN), 2006.
- EN 1993-1-9 // Eurocode 3: Design of steel structures - Part 1-9: Fatigue. - Brussels : European Committee for Standardization (CEN), 2005.
- EN 1993-2 // Eurocode 3 - Design of steel structures - Part 2: Steel Bridges. - Brussels : European Committee for Standardization (CEN), 2006.
- EN 1993-5 // Eurocode 3 - Design of steel structures - Part 5: Piling. - Brussels : European Committee for Standardization (CEN), 2007.
- EN 1994-2 // Eurocode 4 - Design of composite steel and concrete structures - Part 2: General rules and rules for bridges. - Brussels : European Committee for Standardization (CEN), 2005.
- EN 1997-1 // Eurocode 7: Geotechnical design - Part 1: General rules. - Brussels : European Committee for Standardization (CEN), 2005.
- Feldmann, M., Naumes, J., Pak, D., Veljkovic, M., Eriksen, J., Hechler, O., et al., 2010, Design Guide. Aachen: RWTH Aachen University, Institut für Stahlbau, <http://www.bridgedesign.de>

- Emerson, M. (1977). Temperature differences in bridges: basis of design requirements, TRRL Laboratory Report 765, Transport and Road Research Laboratory, Crowthorne, Berkshire, pp. 39.
- Iles D., 2005, "Integral Steel Bridges: A Summary of Current Practice in Design and Construction", SCI Publication P340, p. 8
- Kerokoski O., 2006, Soil Structure Interaction of Long Jointless Bridges with Integral Abutments, Tampere University of Technology, p.16
- Maruri R., Petro S., 2005, Integral Abutments and Jointless Bridges (IAJB) 2004 Survey Summary, Federal Highway Administration (FHWA)/Constructed Facilities Center (CFC) at West Virginia University
- Pétursson H., Möller M., Collin P., 2013, Structural Engineering International, Vol. 23 , Number 3 ,pp. 278-284
- Reese L. C., Cox W. R., Koop F. D., 1974, Analysis of Laterally Loaded Piles in Sand, Offshore Technology Conference, Houston, Paper. No. OTC 2080